

In fase di ordine specificare:

- lunghezza 4 mt. o 8 mt.;
- dimensione dell'attacco es. D.25 o D.50
- tipo della connessione comandi (spinotto) che varia in base ai singoli modelli di saldatrice;
- tipo di pulsante, a una posizione, a 2 o 4 posizioni, con valvola di apertura gas;
- corpo torcia standard, o flessi



Torçe per saldatura Tig

Guida alla scelta della torcia

ciclo di lavoro (A) in corrente continua DC, come definiti da norma EN 60974-7, riferiti ai modelli di torcia "originale Binzel Abitig Grip"; altri modelli costruttivi possono avere cicli di lavoro differenti.

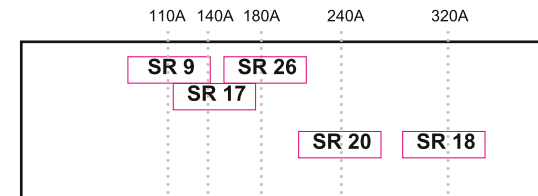

ricambi standard

- 1 - isolante
- A - pinza
- B - portapinza
- C - ugello ceramico
- D - ugello lungo

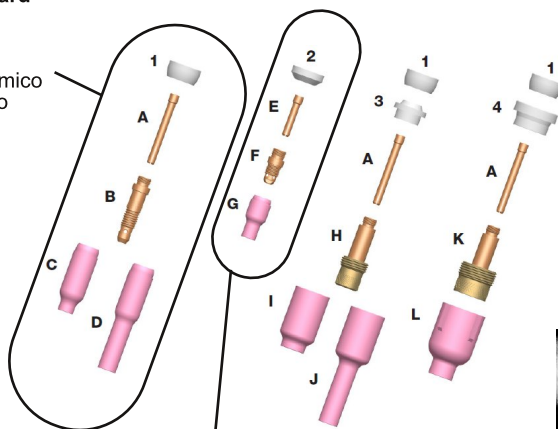

ricambi "gas lens" riducono le turbolenze del gas, garantendo un flusso più preciso; esistono standard, jumbo o large, lunghi



ricambi "stubby" consentono di ridurre l'ingombro della torcia, utilizzando pinza e ugelli delle torçe 9/20 sulle torçe 17/18/26

Misura degli ugelli

La misura del diametro in uscita é espressa sia in mm. che in gr.1/16"



Penna / Cappellotto

Tre lunghezze diverse



Elettrodi di tungsteno

Elettrodi infusibili in tungsteno, con aggiunta di ossidi di elementi rari, lunghezza 175 mm. Diametri disponibili 1,0 - 1,6 - 2,0 - 2,4 - 3,2 - 4,0

In confezioni da 10 pezzi.

- Grigio - WC2
- Rosso - WT
- Verde - WP
- Oro - WL1
- Blu - WL2
- Turchese - WTR
- Porpora - E3

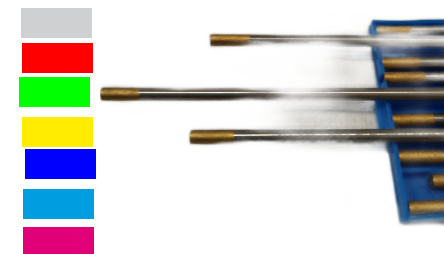

Ricambiistica per torce mod. 17 - 18 - 26

	Penna / Cappellotto	Lunga 57Y02 ●	Media 57Y02 ●	Corta 57Y04 ●			
6	Isolante	18CG ●					
2	Pinza	∅ 1,0 10N22 ●	∅ 1,6 10N23 ●	∅ 2,4 17P-20 ●	∅ 3,2 10N24 ●	∅ 4,0 54N20 ●	∅ 4,8 30028 ●
3	Porta Pinza	∅ 1,0 10N30 ●	∅ 1,6 10N31 ●	∅ 2,4 10N32 ●	∅ 3,2 10N28 ●	∅ 4,0 406488 ●	∅ 4,8 30126 ●
4	Ugello ceramico	Gr.4 ∅ 6,4 10N50 ●	Gr.5 ∅ 8,0 10N49 ●	Gr.6 ∅ 9,8 10N48 ●	Gr.7 ∅ 11,2 10N47 ●	Gr.8 ∅ 12,7 10N46 ●	Gr.10 ∅ 15,7 10N45 ●
4a	Ugello ceramico lungo		Gr.5 ∅ 8,0 10N49L ●	Gr.6 ∅ 9,8 10N48L ●	Gr.7 ∅ 11,2 10N47L ●		
7	Porta Pinza Gas Lens	∅ 1,0 45V24 ●	∅ 1,6 45V25 ●	∅ 2,4 45V26 ●	∅ 3,2 45V27 ●	∅ 4,0 45V28 ●	
8	Ugello ceramico Gas Lens	Gr.4 ∅ 6,4 54N18 ●	Gr.5 ∅ 8,0 54N17 ●	Gr.6 ∅ 9,8 54N16 ●	Gr.7 ∅ 11,2 54N15 ●	Gr.8 ∅ 12,7 54N14 ●	
8a	Ugello ceramico Lungo Gas Lens		Gr.5 ∅ 8,0 54N17L ●	Gr.6 ∅ 9,5 54N16L ●	Gr.7 ∅ 11,2 54N15L ●		

Gr.11 ∅ 19,0
54N19 ●

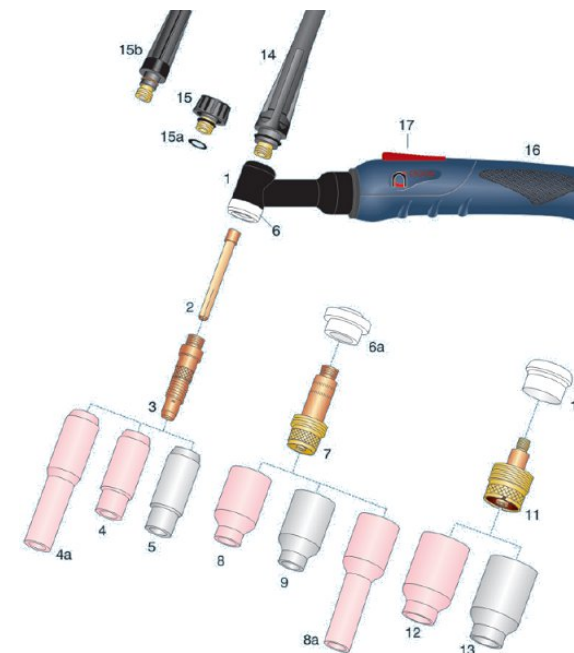

Ricambiistica per torce mod. 9 - 20

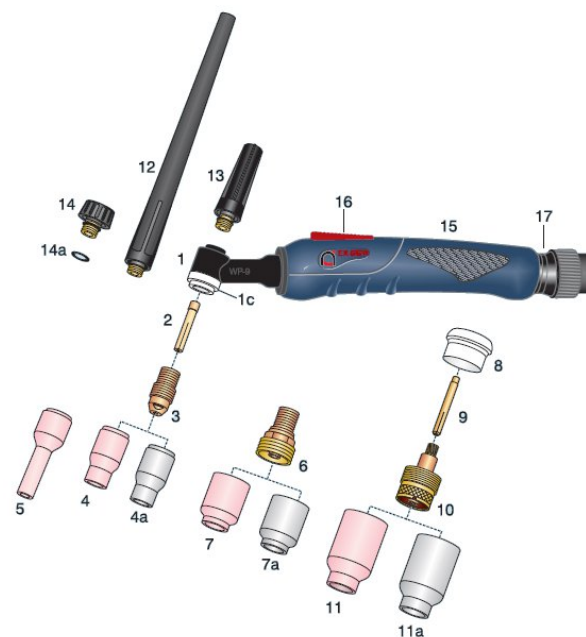

1	Penna / Cappellotto	Lunga 41V24 ●	Media 41V35 ●	Corta 41V33 ●		
6	Isolante	598882 ●				
2	Pinza	∅ 1,0 13N21 ●	∅ 1,6 13N22 ●	∅ 2,4 10N23 ●	∅ 3,2 13N24 ●	
3	Porta Pinza	∅ 1,0 13N26 ●	∅ 1,6 13N27 ●	∅ 2,4 13N28 ●	∅ 3,2 13N29 ●	
4	Ugello ceramico	Gr.4 ∅ 6,4 13N08 ●	Gr.5 ∅ 8,0 13N09 ●	Gr.6 ∅ 9,8 13N10 ●	Gr.7 ∅ 11,2 13N11 ●	Gr.8 ∅ 12,7 13N12 ●
						Gr.10 ∅ 15,7 13N13 ●

Torce e ricambi per saldatura tig